

# FireLock® Zone Control Riser Module

SERIES 747M



SEE VICTAULIC PUBLICATION 10.01 FOR DETAILS

Designed for NFPA 13 commercial requirements, the Victaulic Series 747M Zone Control Riser Module features a cast body, and is compact and easy to install in zoned wet sprinkler systems. The integrated module body consists of a shut off valve, test and drain valve combination and different orifice sizes (K factors), a UL Listed and FM Approved Flow Switch, and a Pressure Gauge. The Series 747M FireLock Zone Control Riser Module is available in sizes from 1 1/4 through 6 3/32 – 150mm with grooved ends on the main pipe for installation in the horizontal or vertical up-flow positions with UL Listed, FM Approved Victaulic grooved couplings. 1 1/4 - 2" modules have an NPT drain port. 2 1/2 - 6" modules have a grooved drain port. The Series 747M FireLock Zone Control Riser Module is FM Approved for working pressures up to 365psi/2517kPa and is UL and ULC Listed for working pressures up to 300psi/2068kPa. An optional pressure relief valve kit is available for all sizes. The Pressure Relief Valve is FM Approved and UL and ULC Listed for working pressures up to 175psi/1200kPa.



STYLE 747M  
PATENT PENDING

## DIMENSIONS

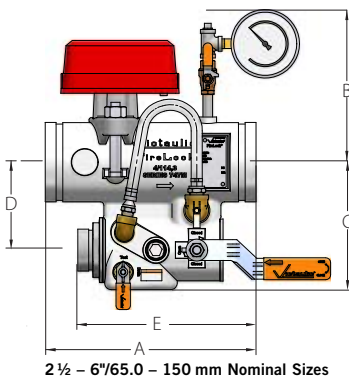
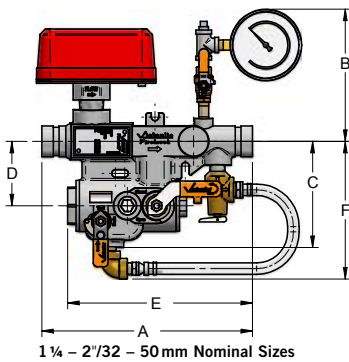

Module Body Size			Dimensions – Inches/mm							Aprx. Weight Each
Nominal Diameter Inches/mm	Actual Outside Diameter Inches/mm	Drain Size Inches/mm	A	B	C	D	E (Groove)	F	Lbs./kgs	
1 1/4 32	1.660 42.2	1 33.4	11.45 290.8	7.20 182.9	5.77 146.5	3.50 88.9	10.05 255.3	7.48 190.0	15.2 6.9	
1 1/2 40	1.900 48.3	1 33.4	11.45 290.8	7.32 185.9	5.77 146.5	3.50 88.9	10.05 255.3	7.48 190.0	15.5 7.0	
2 50	2.375 60.3	1 33.4	11.45 290.8	7.55 191.8	5.77 146.5	3.50 88.9	10.05 255.3	7.48 190.0	19.9 9.0	
2 1/2 65	2.875 73.0	1 1/4 42	12.00 305	8.41 214	6.18 157	4.25 108	9.76 248	–	22.7 10.3	
3 80	3.500 88.9	1 1/4 42	12.00 305	9.42 239	6.18 157	4.25 108	9.76 248	–	23.2 10.6	
4 100	4.500 114.3	2 60	12.00 305	9.90 252	7.25 184	5.00 127	10.15 258	–	30.3 13.8	
6 150	6.625 168.3	2 60	12.00 305	10.85 276	8.31 211	6.00 154	10.15 258	–	36.7 16.7	

Nominal Size inches	Orifices	
	Orifices	
1.25	K5.6	
1.5	K5.6	
2	K5.6	
2.5	K5.6 K6.9 K8.0 K11.2	
3	K5.6 K6.9 K8.0 K11.2	
4	K5.6 K6.9 K8.0 K11.2 K14.0 K16.8	
6	K5.6 K6.9 K8.0 K11.2 K14.0 K16.8	

(Valves shown above in the "test" position. Shown with optional Pressure Relief Valve Kit installed)

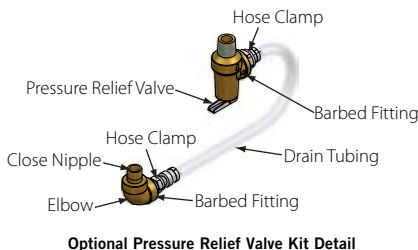

Nominal Size inches	Drain Type	Drain Size
1.25	NPT	1"
1.5	NPT	1"
2	NPT	1"
2.5	Grooved	1 1/4"
3	Grooved	1 1/4"
4	Grooved	2"
6	Grooved	2"

### JOB/OWNER

System No. \_\_\_\_\_  
Location \_\_\_\_\_

### CONTRACTOR

Submitted By \_\_\_\_\_  
Date \_\_\_\_\_

### ENGINEER

Spec Sect \_\_\_\_\_ Para \_\_\_\_\_  
Approved \_\_\_\_\_  
Date \_\_\_\_\_

# FireLock® Zone Control Riser Module

SERIES 747M

## MATERIAL SPECIFICATIONS

**Module Body:** Cast from ductile iron conforming to ASTM A-536, grade 65-45-12 with integral Victaulic grooved ends. Finish: orange enamel.

**Shut-off and Test/Drain Valve:** Chrome plated brass ball, S 37700 brass clapper, 416SS or 410SS shafts, Delrin orifice, virgin Teflon\*, enhanced Teflon and EPDM rubber seals.

\*Teflon is a registered trademark of Dupont

**Coupling:** Any UL Listed, FM Approved Victaulic coupling may also be used. Note: Couplings not included with product.

**Waterflow Detector:** System Sensor Model WFD/WFDTH vane type waterflow detector with sealed retard, visual switch activation, and mechanical delay adjustment. Cover includes tamper resistant security screws and tool. Note: ULC models WFDA /WFDTHA include cover tamper switch.

## WARRANTY



Refer to the Warranty section of the current Price List or contact Victaulic for details.

## NOTE

This product shall be manufactured by Victaulic or to Victaulic specifications. All products to be installed in accordance with current Victaulic installation/assembly instructions. Victaulic reserves the right to change product specifications, designs and standard equipment without notice and without incurring obligations.

## WARNING



 <b>WARNING</b>	
	<ul style="list-style-type: none"> <li>• <b>This product must be installed by an experienced, trained installer, in accordance with the instructions provided with each valve. These instructions contain important information.</b></li> </ul> <p>Failure to follow these instructions may result in serious personal injury, property damage, or valve leakage.</p> <p>If you need additional copies of this product literature or the valve installation instructions, or if you have any questions about the safe installation and use of this device, contact Victaulic Company, P.O. Box 31, Easton, PA 18044-0031 USA, Telephone: 001-610-559-3300.</p>

For complete contact information, visit [www.victaulic.com](http://www.victaulic.com)

10.96 3089 REV H UPDATED 2/2009

VICTAULIC IS A REGISTERED TRADEMARK OF VICTAULIC COMPANY. © 2009 VICTAULIC COMPANY. ALL RIGHTS RESERVED.

10.96

