

## AWWA Grooved Piping Method

Pipe of AWWA dimensions can be joined quickly and easily with the Victaulic grooved piping method. Victaulic products and recommendations conform to ANSI/AWWA C-606, Standard for Grooved and Shouldered Type Joints and CSA 242 M1980.

The groove configuration for ductile (cast) pipe includes a large radius, eliminating sharp corners and stress concentration. This provides stronger beam load capability and higher working pressures for radius grooved systems than available with conventional flanged systems.

### FlushSeal® Gasket

The FlushSeal® gasket is designed specifically to seal on ductile iron pipe surfaces. It provides a triple-seal to assure leak-free service for the life of the system.

- 1 Stretching the Victaulic gasket over pipe ends puts the angular lips in immediate and automatic sealing tension.
- 2 Gasket center leg is compressed over pipe ends as coupling is assembled.
- 3 Line pressure automatically strengthens the seal by acting internally on the gasket lips – the higher the pressure, the tighter the seal.

### Rigid or Flexible Grooving

Grooving can be done quickly and easily in the field or shop. Standard "Rigid" radius grooving provides the ease of grooved pipe assembly in a rigid joint. The design of the groove and Victaulic coupling draws the pipe ends into contact as the coupling is tightened.

Where flexibility is desirable, "flexible" radius groove dimensions should be used. Flexible grooving provides the added advantages of expansion, contraction and deflection. This is useful to accommodate movement from thermal changes, settling, seismic effect or other causes.

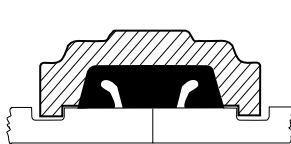
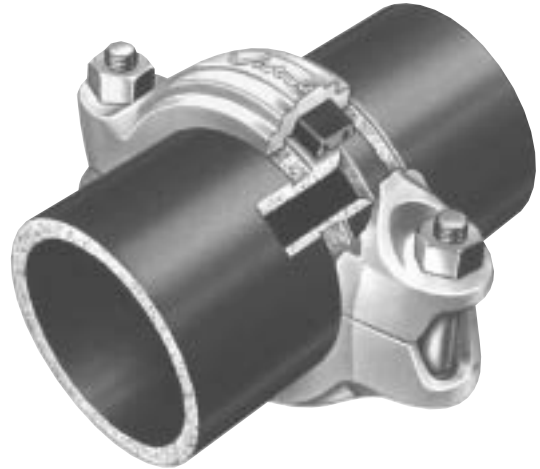

**Rigid Radius Cut Groove**

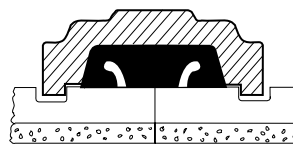

**Cement Lined Pipe**

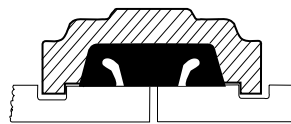

**Flexible Radius Cut Groove**

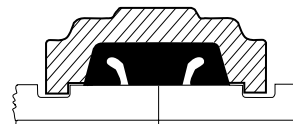

**Glass Lined**

*Exaggerated for clarity*

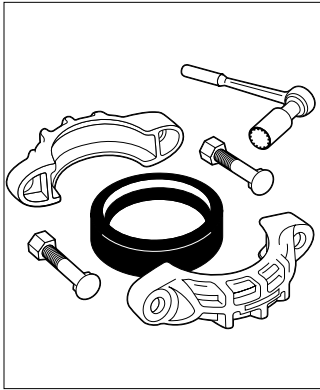

**Installed cost savings from 10% to 30%**

- Minimal equipment investment
- Fast assembly in tight places
- Clean system. . . no pipe dope or welding slag to contaminate pipes
- Costs are more predictable. . . estimates more accurate

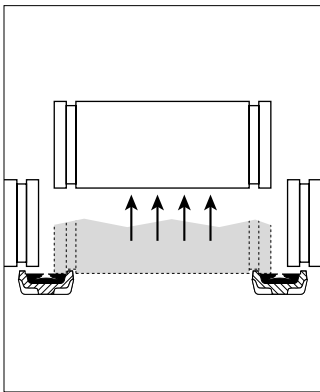

**Each joint is a union**

- Removal of two couplings permits removal of pipe section for cleaning or servicing
- Easy future add-on, change or renovation of pipe to distribute internal wear from abrasives or slurries
- **WARNING: Depressurize and drain the piping system before attempting to install, remove, or adjust any Victaulic piping products.**

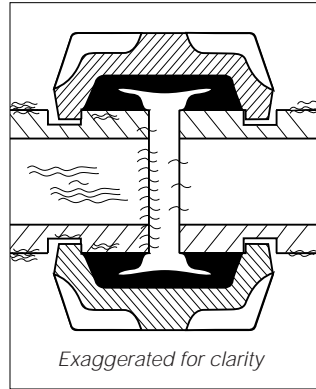

**Proven joint reliability**

- Full circumferential engagement of housing into groove provides end pull strength
- Couplings available for working pressures to 2,500 psi (17,235 kPa). . . vacuum services to 29.9" Hg

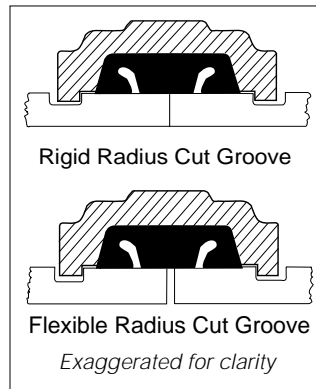

**Rigidity or flexibility**

**Rigid Radius Cut Groove**

- Prevents expansion/contraction
- Ideal for long pipe runs
- Designed for systems with cycling pressure

**Flexible Radius Cut Groove**

- Allows up to 0.47" of expansion/contraction
- Ideal for uneven surfaces or where settlement is expected

**VICTAULIC SYSTEM ELIMINATES ALIGNMENT PROBLEMS**

<p><b>Victaulic</b> Rotates for Alignment</p>	<p><b>Flanged</b> Must be "two holed"</p>	<p><b>Victaulic</b> 54" Typical</p>	<p><b>Flanged</b> 54" Typical</p>
<ul style="list-style-type: none"> <li>• Grooved piping can pass through wall sleeves</li> <li>• Special design considerations eliminated</li> <li>• Compression type couplings not required</li> </ul>	<ul style="list-style-type: none"> <li>• Require special design considerations</li> <li>• Flanging must be made-on loose or have coupling adapter added to pass through a wall sleeve</li> </ul>	<ul style="list-style-type: none"> <li>• No two-holing required</li> <li>• No space needed for bolts</li> <li>• 1/3 the weight of flanged systems</li> <li>• Number of bolts greatly reduced</li> </ul>	<ul style="list-style-type: none"> <li>• Two-holing required</li> <li>• Side space needed for bolts</li> <li>• Heavier, more costly to install</li> <li>• More bolts, longer installation time</li> </ul>

This product shall be manufactured by Victaulic Company. All products to be installed in accordance with current Victaulic installation/assembly instructions. Victaulic reserves the right to change product specifications, designs and standard equipment without notice and without incurring obligations.