



VICTAULIC BERMAD TECHNOLOGIES  
 9424 West Little York Road  
 Houston, Texas 77040  
 800 821 6825

victaulic.com | bermad.com

## PREVENTATIVE MAINTENANCE INSTRUCTIONS

### **1. EXTERNAL INSPECTION & MAINTENANCE**

*To be completed within the first week of operation and every 6 months thereafter.*

#### **1.1. Inspect Main Valve & Control Loop for Leaks**

#### **1.2. Inspect Pilot Weep Hole\***

*Located on the side of the pilot's cover*

1.2.1. Verify that there is nothing plugging the weep hole.

1.2.2. Look for signs of water coming out of the weep hole. If there is water, the pilot's diaphragm may need to be replaced.

#### **1.3. Inspect Drain Line(s)\* and/or Vent Port(s)\* for Plugs**

#### **1.4. Verify Actuator & Cover Bolts are Tight**

#### **1.5. Verify Lock Nuts on Pilot(s)\* & Needle Valve(s)\* are Tight**

#### **1.6. Clean Control Filter#**

1.6.1. Close ball valves 1, 2 and 3 to isolate the control loop.

1.6.2. Loosen the tube connection above the filter and bleed and trapped pressure.

1.6.3. Loosen the filter cap and remove the filter element.

1.6.4. Inspect and clean the filter by cracking open ball valve 1 for wash water. Clean the filter element with a stiff brush.

1.6.5. You must be able to blow through the filter screen. Often the cavity is free of dirt, but the filter is packed.

#### **1.7. Cycle the Main Valve Fully Open & Closed#**

##### 1.7.1. Open Valve Test

1.7.1.1. Close only ball valve 1, the ball valve on the upstream side of the valve.

1.7.1.2. Water is prevented from entering the cover and the valve will drift open to its maximum open position.

1.7.1.3. To get the valve to open to an even wider position, close ball valves 1, 2 and 3, and loosen the tubing connection to ball valve 3. Crack open ball valve 3; this will vent out all trapped pressure and allow the valve to go to its full open travel stop. This extra wide open position is unattainable while the valve is functioning in normal service. Trapped pressure is necessary for control response.

##### 1.7.2. Closed Valve Test

1.7.2.1. Close only ball valve 2, the ball valve on the downstream side of the valve.

1.7.2.2. Pressure will build up in the cover, and the valve will close. This may take from a few seconds to a few minutes, depending on the valve size and pipeline pressure.

1.7.2.3. If the valve does not close, or is much slower than previously, inspect the filter and/or check the diaphragm.

1.7.2.4. If the valve goes part way closed and stops, inspect the inside of the valve for obstructions.

*\*Not all valves will have each component (Pilot, Solenoid, Needle Valve, etc.), and some may have more than one of each.*

*#Some valve's may not have all three ball valves mentioned. Consult each valve's IOM for more information regarding the control loop. Contact the factory for more information.*

**1.8. Verify Main Valve Sealing<sup>#</sup>**

- 1.8.1. Install a pressure gauge on the downstream port of the main valve, or on the downstream side of the control loop.
- 1.8.2. Close ball valve 2 to force the valve closed.
- 1.8.3. Close the downstream isolation valve.
- 1.8.4. Watch the pressure on the gauge for any upward drift. If after a few minutes, the pressure has remained constant, the valve has sealed closed. If the pressure has risen, it may be necessary to inspect the seat and seal.

**1.9. Verify Limit Switch Bolts are Tight****1.10. Check Position Indicator**

- 1.10.1. Firmly grip the indicator rod.
- 1.10.2. Turn the indicator rod along its main axis to verify freedom of rotation.
- 1.10.3. Examine the Indicator Rod for any bends along its length.
- 1.10.4. If the indicator rod cannot rotate or is bent, it should be replaced.

**1.11. Open & Close Ball Valve(s) to Verify Operation****1.12. Energize & De-energize Solenoid(s) to Verify Operation**

*\*Not all valves will have each component (Pilot, Solenoid, Needle Valve, etc.), and some may have more than one of each.*

*#Some valve's may not have all three ball valves mentioned. Consult each valve's IOM for more information regarding the control loop. Contact the factory for more information.*



VICTAULIC BERMAD TECHNOLOGIES  
 9424 West Little York Road  
 Houston, Texas 77040  
 800 821 6825

victaulic.com | bermad.com

**2. INTERNAL INSPECTION & MAINTENANCE**

*To be completed after every 2 years of operation.*

**2.1. Remove & Replace (or Re-calibrate) Pressure Gauge(s)\***

**2.2. Remove Actuator Assembly#**

- 2.2.1. Close the upstream and downstream isolation valves.
- 2.2.2. Close ball valves 1, 2 and 3 to isolate the control loop.
- 2.2.3. Remove the tubing. Loosen first and wait until all trapped pressure bleeds out. Mark all connection for orientation at reassembly.
- 2.2.4. Vent trapped pressure from both the inlet and outlet sides of the valve by either slowly opening ball valves 1 and 2, or slowly removing the plugs from the body pots.
- 2.2.5. Loosen and remove the nuts holding the actuator to the main valve body. This is the lower ring of nuts with the smaller diameter bolt circle. Do not remove the upper ring of nuts which hold the two halves of the actuator together. The actuator will lift out easily, but may have to be loosened. A pry bar or tap with a mallet will loosen paint, dirt, or rust. **Warning:** Do not begin loosening the actuator nuts without first venting the trapped pressure.
- 2.2.6. Remove the actuator and pilot(s) as one complete assembly. Do not lose or damage the cover O-ring. Mark the actuator for orientation at reassembly.

**2.3. Inspect Body & Cover Ports**

- 2.3.1. Check for signs of mineral build-up around and in the ports.
- 2.3.2. If any build-up exists, use a hammer and chisel or punch to knock off body to prevent the ports from clogging. If the build-up is inside the ports, use a tap to clean the threads once the mineral deposit has been knocked out.
- 2.3.3. On modulating models, i.e. 720, 723, 730, 770, inspect the bulkhead holes in the bottom of the actuator. They should be open and allow water passage. On on-off models i.e. 710, 74Q inspect the holes on the side of the actuator. They should be open and allow air to vent. Mud wasp screens may be needed in some areas.

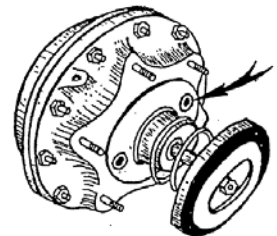

**2.4. Inspect Body & Seat**

- 2.4.1. Look for any signs of pitting due to cavitation. If there is sever pitting, the body should be replaced.
- 2.4.2. Inspect the seat and smooth with fine grit emery paper if necessary.

**2.5. Inspect Actuator Parts:**

- 2.5.1. Make sure the actuator has freedom of motion. Push and pull the actuator shaft. It should stoke freely. Air may be heard rushing into and out of the bulkhead holes.
- 2.5.2. If the disc and shaft do not move up and down freely, there may be dirt in the bearing, dirt or sand in the operating chambers, mineral deposits on the shaft, or a bent indicator rod. The actuator may require disassembly to clean.

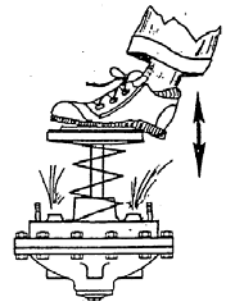

*\*Not all valves will have each component (Pilot, Solenoid, Needle Valve, etc.), and some may have more than one of each.*

*#Some valve's may not have all three ball valves mentioned. Consult each valve's IOM for more information regarding the control loop. Contact the factory for more information.*



### **3. DIAPHRAGM / ELASTOMER REPLACEMENT**

- 3.1. An 8" valve diaphragm can be replaced in about one hour. There are no special sequences of disassembly required. No special tools are needed. The spare parts drawing can be used to aid in disassembly and reassembly.
- 3.2. Customers with many valves in their systems should stock spare actuators. The actuator with pilot is switched in the field in minutes, and the removed actuator is overhauled in the shop.
- 3.3. Draw a marking line along the side of the valve actuator so all parts can be realigned and all brackets put back in the exact same location. Remove the bottom lock nut (7), seal disc nut (8), and seal disc (39). The spring can easily be compressed.
- 3.4. Remove the cover screws (12) and cover (20). The entire shaft can now be pulled out with the diaphragm attached to the shaft.
- 3.5. Remove the shaft nuts (18) and (19). Note: it may be difficult to remove these because they are put on with Loctite. If this is the case, put the bottom nuts (7) and (8) back on and use them to grip the shaft and keep it from turning. **DO NOT GRIP THE SHAFT DIRECTLY WITH A PIPE WRENCH!** Use a protective piece of rubber on the jaws. A scar on the shaft finish could damage the O- ring or bearing.
- 3.6. Inspect the bearing (23). Bearing rarely needs to be replaced. The bearing is easy to remove. It is not press fit or bonded into the housing. Removing the locking bolts will allow the entire bearing to be removed.
- 3.7. Inspect the shaft. Mineral deposits can collect on the shaft which will make it stick in the bearing. Wet sand with fine emery cloth and lubricate lightly before re-use.
- 3.8. Inspect the vent holes in the actuator bottom partition. Most on/off valves have ¼" NPT pipe plugs. Most modulating valves have ¼" NPT plugs with an orifice hole in them. If there are orifice holes, be sure they are clear and open. The orifice has been carefully calculated to allow a fixed rate of passage of water which prevents slamming or runaway opening. **DO NOT** remove the plugs. Do not reinstall full plugs if there are holes.
- 3.9. Once the nuts are removed the diaphragm assembly can be taken apart. **Warning:** Pay attention to the installation of the small washer (16) and the O- ring (17). On the new diaphragm, they must be installed exactly as they were on the old diaphragm.
- 3.10. Install the new diaphragm on the shaft. Place the assembly into the bottom partition. **Warning:** when pushing the shaft through the bearing be careful not to nip the O- ring with the shaft. Push slowly with a slight rotating motion with a well lubricated shaft.
- 3.11. The diaphragm is slightly larger in diameter than the top and bottom cover (parts 20 and 27). This gives the diaphragm its flex but makes it slightly tricky to bolt up. It is easiest to rest the bottom partition (27) on a block of wood. Next place a shim or piece of wood under the shaft to lift it slightly ½" to 1". This will create a floppy "umbrella effect" with the diaphragm. Once the proper "drape" or "umbrella" is obtained, tuck the edge of the diaphragm into the lip around the outside edge of the bottom partition.
- 3.12. Reinstall the top cover carefully by letting it gently down on the diaphragm. Line up the cover with the same indication line drawn in Step 3. Install the bolts and tuck in the diaphragm as you go.
- 3.13. Reinstall the spring, disc, seal disc nut (8), and lock nut (7).
- 3.14. Make sure actuator has freedom of motion. Push and pull the actuator shaft. It should stroke freely. Air may be heard rushing into and out of the bulkhead holes.
- 3.15. Reassemble the actuator to the body lining up the marks as drawn in Step 3.3.

*\*Not all valves will have each component (Pilot, Solenoid, Needle Valve, etc.), and some may have more than one of each.*

*#Some valve's may not have all three ball valves mentioned. Consult each valve's IOM for more information regarding the control loop. Contact the factory for more information.*



VICTAULIC BERMAD TECHNOLOGIES  
9424 West Little York Road  
Houston, Texas 77040  
800 821 6825

victaulic.com | bermad.com

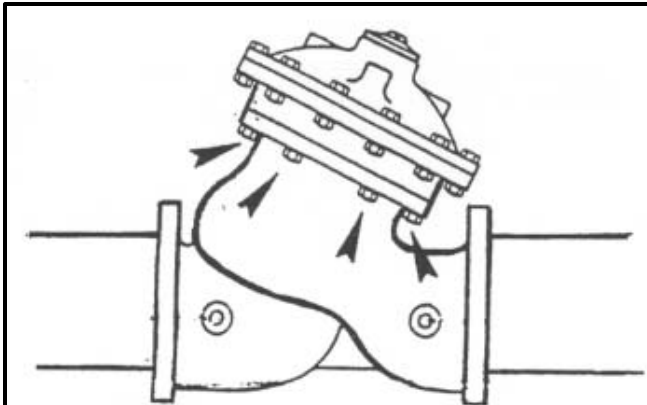

Fig. 1 Make sure the valve is isolated and there are no leaking gate valves. Any trapped pressure must be drained from the valve body. Remove the actuator nuts from the bottom flange. Do not loosen the top flange nuts.

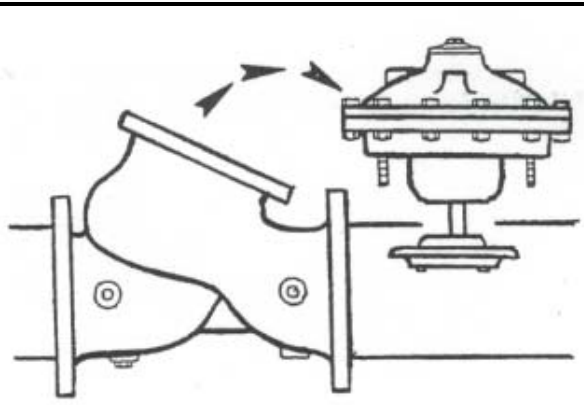

Fig. 2 The actuator lifts out in one complete assembly. Inspect the seat and seal.

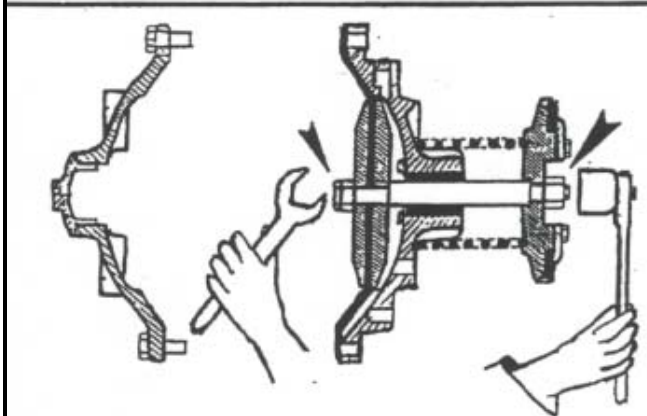

Fig. 3 Remove the top cover. Remove the bottom shaft nut by also gripping the top nut with a wrench. Remove seal disc and spring. The diaphragm assembly and shaft can now be pulled out.

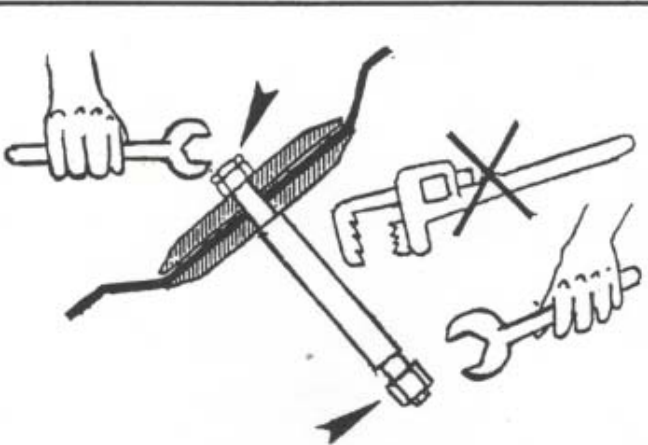

Fig. 4 Avoid putting a pipe wrench directly on the shaft. Use a protective pad or reinstall the bottom shaft nuts to use as gripping nuts when loosening the top shaft nut.

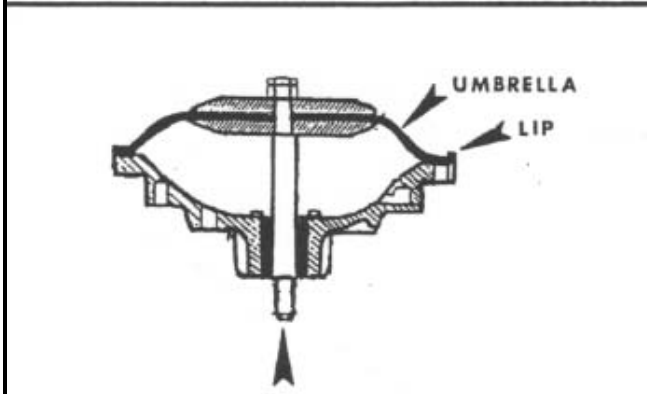

Fig. 5 To reinstall the diaphragm form an umbrella by forcing the shaft upwards. Align all holes. Tuck the edge of the diaphragm into the lip on bottom partition

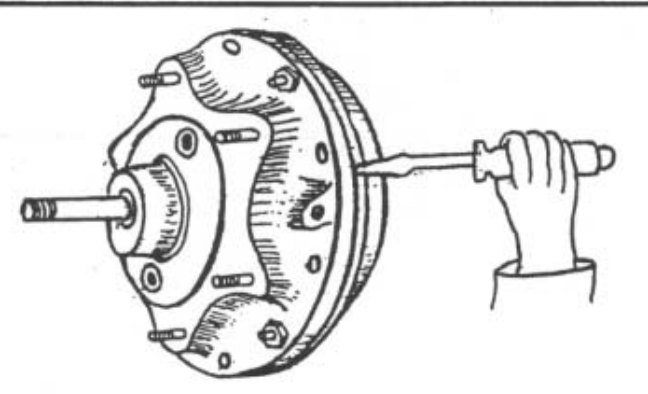
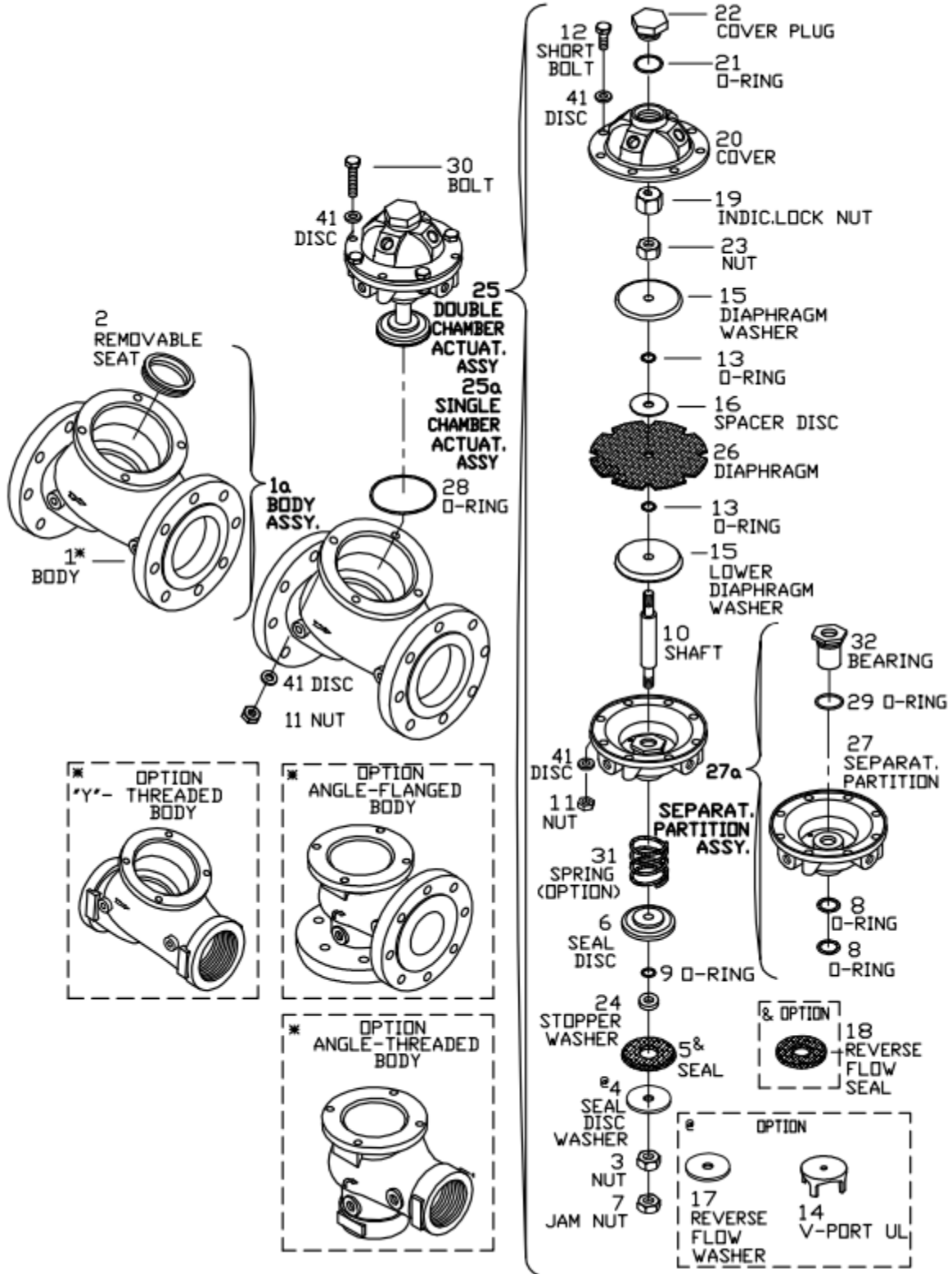

Fig. 6 Install top cover using two opposing bolts for alignment. Tuck in any protruding edge of the diaphragm with a screwdriver as you work around the circumference installing bolts.



**Diaphragm Actuated Basic Control Valves**

Size: 1 1/2", 2", 2 1/2" & 3"R



**Diaphragm Actuated Basic Control Valves**  
 Size 3" & 4"R

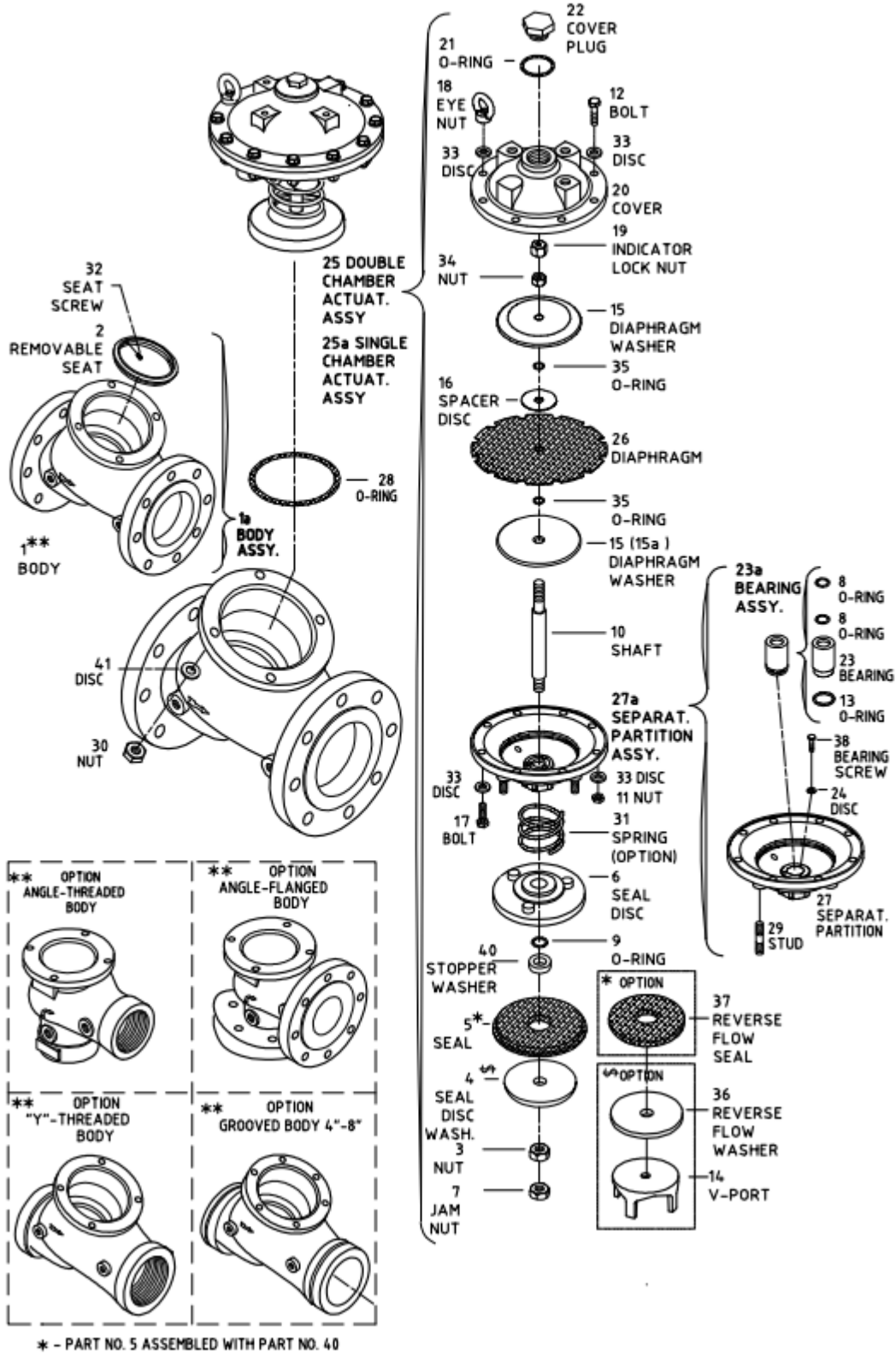

**Diaphragm Actuated Basic Control Valves**  
 Size 4" - 20"

