

Series 717R Riser Check Kit For Series 717R FireLock™ Check Valve

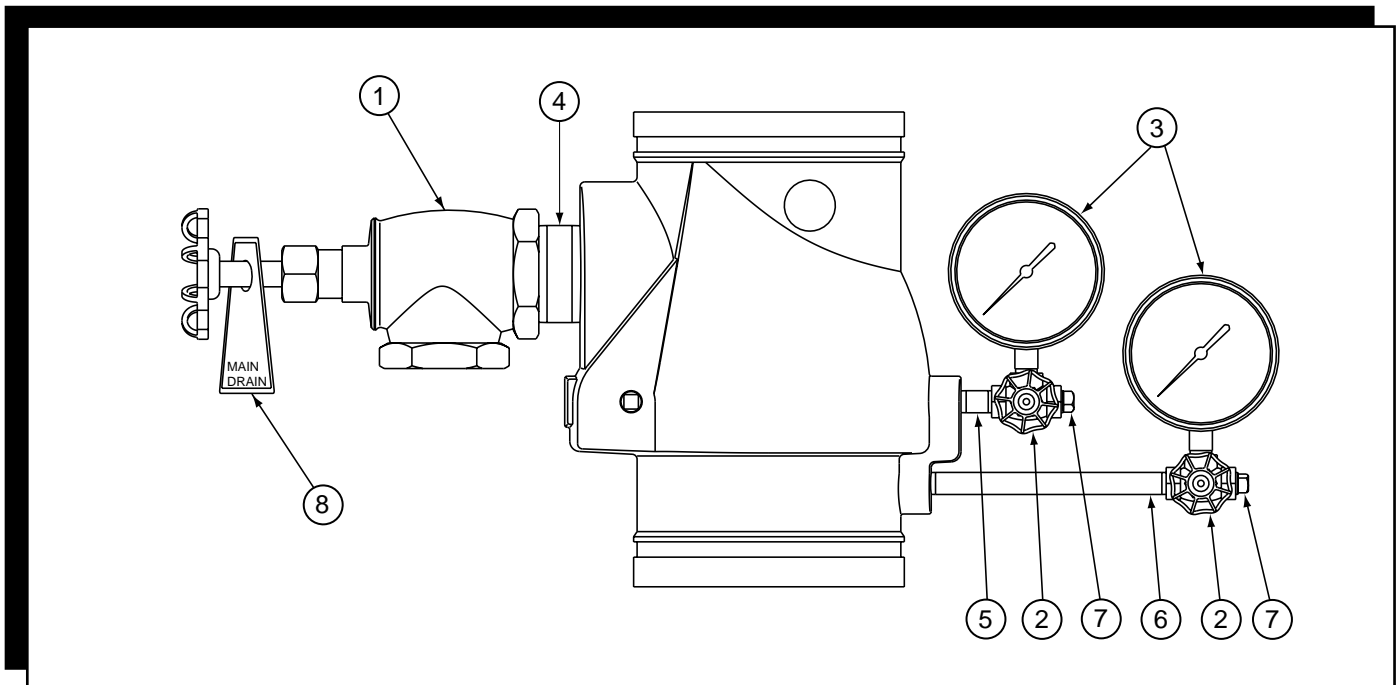
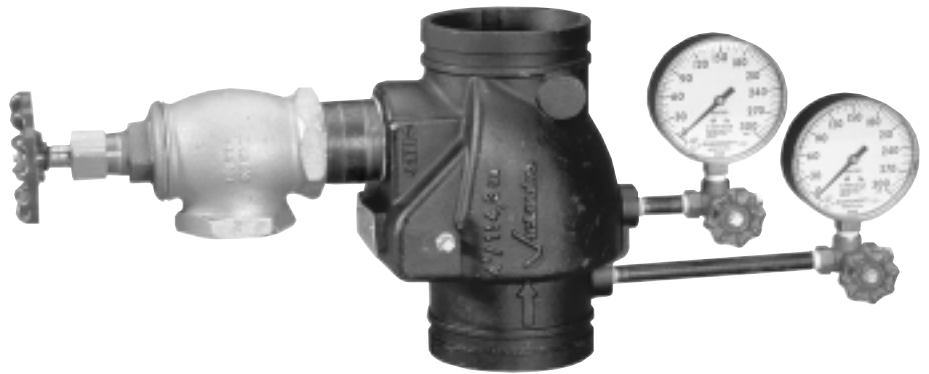

Replacement Parts		Parts Description
Item	Quantity	
1	1	2" 90° Angle Valve
2	2	1/4" NPT 3 Way Gauge Test Valve
3	2	3 1/2" Diameter Water Pressure Gauge 0-300 PSI, 1/4" NPT Bottom Connection
4	1	Pipe Nipple 2" Schedule 40 X 2 1/2" Long Thread Both Ends
5	1	Pipe Nipple 1/4" Schedule 40 X 2" Long Thread Both Ends
6	1	Pipe Nipple 1/4" Schedule 40 X 6 1/2" Long Thread Both Ends
7	2	Pipe Plug 1/4" NPT Square Head
8	1	Drain Tag

KIT INSTALLATION INSTRUCTIONS

The Series 717R with the kit installed is UL/ULC Listed and FM Approved for working pressure of 200 PSI (1380 kPa) or indoor or outdoor use. The standard disc material is EPDM and is recommended for water and oil-free air service. **THIS MATERIAL IS NOT RECOMMENDED FOR PETROLEUM SERVICES.**

Following are instructions for installing the riser check kit onto 4 through 8 - inch Series 717R FireLock check valves. Refer to the table shown above to be certain you have received all the proper parts for this kit. Before beginning installation verify that the valve is a Series 717R (see tag on the body) that has been drilled and tapped for mounting the kit to the valve.

WARNING

Failure to follow instructions and warnings can result in serious personal injury, property damage or death.

- Do not service any valve that is pressurized or contains harmful fluids or gasses.
- Before installing, operating, or servicing, read and understand the Operating Instructions and all warning labels.
- Always wear safety glasses and foot protection.

If you have any questions about the safe operation of this tool, contact Victaulic, P.O. Box 31, Easton, PA 18044-0031, 610-559-3300.

I. Assembly of Series 717R Riser Check Kit



Step 1: Remove 2" (50 mm) NPT pipe plug.



Step 2: Apply suitable pipe dope or teflon tape to the 2" (50 mm) nipple (Item #4).



Step 3: Install the 2" (50 mm) nipple (Item #4) in the Series 717R valve body.



Step 4: Remove both 1/4" (6.4 mm) NPT pipe plugs.



Step 5: Assemble the 1/4" X 2" (6.4 X 50 mm) long nipple (Item #5) and a 1/4" 6.4 mm pipe plug (Item #7) to the 1/4" (6.4 mm) NPT three way globe test valve (Item #2) as shown using suitable pipe dope or teflon tape.

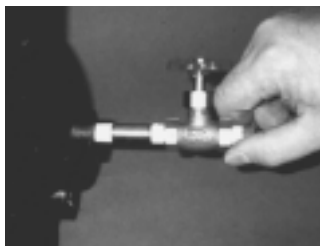

Step 6: Connect the valve/nipple assembly from step 5 to the Series 717R main valve at the downstream port as shown.



Step 7: Install the water pressure gauge (Item #3).



Step 8: Assemble the 1/2" X 6 1/2" (15 X 165 mm) long nipple (Item #6) and the 1/4" pipe plug (Item #7) to the remaining 1/4" NPT three way globe test valve (Item #2) using a suitable teflon tape or pipe dope.

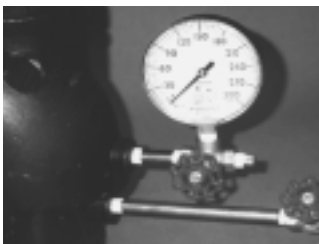

Step 9: Connect the valve nipple assembly from the previous step to the Series 717R valve at the upstream port as shown.



Step 10: Install the remaining water pressure gauge (Item #3).



Step 11: Install the 2" (50 mm) 90° angle valve (Item #1).

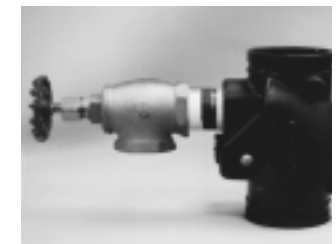

Step 12: Clip the drain tag (Item #8, not shown) onto the angle valve handwheel shaft.