

Automatic Balancing Valves

SERIES 76T VALVE, SERIES 76K VALVE WITH UNION INLET, SERIES 76B VALVE WITH BALL VALVE, SERIES 76V VALVE WITH UNION INLET AND BALL VALVE, AND SERIES 76S VALVE WITH SWEAT ENDS

⚠ WARNING	
	<ul style="list-style-type: none"> • Read and understand all instructions before attempting to install any Victaulic products. • Depressurize and drain the piping system before attempting to install, remove, or adjust any Victaulic products. • Wear safety glasses, hardhat, and foot protection during installation. <p>Failure to follow these instructions could result in serious personal injury and property damage.</p>

INTRODUCTION

Victaulic Automatic Balancing Valves are rated to 365 psi/25 Bar working pressure within a temperature range of -4° F/-20° C minimum to 248° F/120° C maximum.

Options include MNPT, FNPT, or sweat union inlets, isolation ball valve outlets, and sweat adapter inlets and outlets. Multiple options are available for accommodating various flow rates. Refer to the following page for details.

MAKING THE THREADED CONNECTIONS

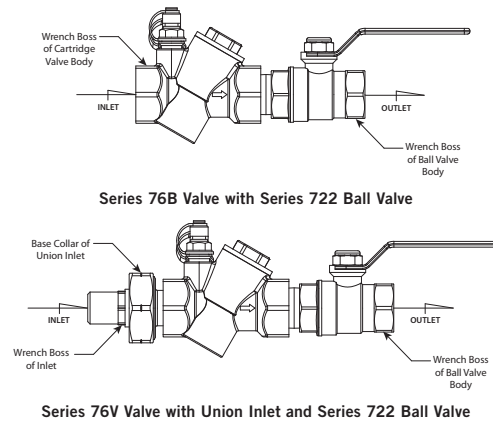
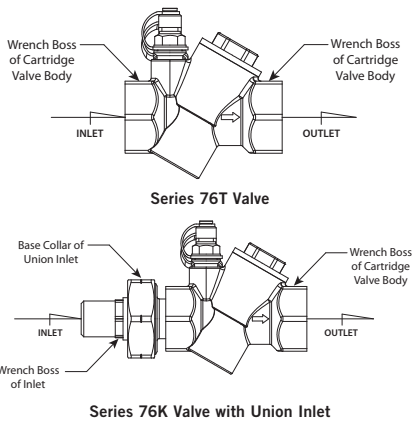

1. Make sure all threaded connections are clean and free of any burrs. Apply a small amount of pipe joint compound or Teflon* tape to the external threads of all threaded pipe connections. DO NOT use a combination of tape and pipe joint compound. DO NOT get any tape, pipe joint compound, or other foreign material into the flow path. During installation, use a pipe wrench ONLY on the wrench bosses or base collars indicated in the drawings above. **NOTE:** For Series 76B and Series 76V, use caution to prevent unthreading the Series 722 Ball Valve from the Series 76T valve body.

MAKING THE SOLDERED CONNECTIONS

Sweat adapters are provided separately and can be soldered or brazed to the pipe ends by following standard piping installation practices. DO NOT install the valve assembly to the sweat adapter until the soldering/brazing process is complete. For connections that require a sweat adapter on each side of the valve body, thread the valve body into one sweat adapter, then make the other connection with a threaded union.

INSTALLATION REQUIREMENTS

1. The Victaulic Automatic Balancing Valve assembly can be installed in the supply or return line. However, Victaulic recommends installing the valve assembly in the return line to reduce noise, flow instability, and entrapped air. An isolation ball valve should be installed in the return line of the system, and a Y-strainer with a blow-down valve should be installed in the supply line upstream of the balancing valve.

1a. Make sure the flow direction arrow on the Series 76T Valve body is facing the direction of flow and that the Series 76T Valve body is rotated to the desired position. **NOTE:** Victaulic recommends installing the Series 76T Valve body so that the pressure/temperature ports are pointing straight upward or located horizontal to the pipeline. To prevent plugging of the ports, do not install the Series 76T Valve body with the pressure/temperature ports pointing straight downward.

2. **FLUSH THE PIPING SYSTEM BEFORE INSTALLING THE CARTRIDGE.** Verify that the proper cartridge for the required flow rate is available. The Series 76T Valve body will be packaged and shipped with the cartridge and identification tag tied to the body. Refer to the "Quick Reference for Orifice Plate and Cartridge Markings" table on the following page.

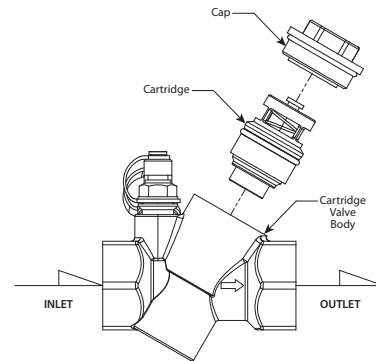

3. Remove the cap from the Series 76T Valve body. Install the cartridge with the flow orifice toward the inside of the Series 76T Valve body, as shown above.

3a. Tighten the cap into the Series 76T Valve body until metal-to-metal contact occurs.

NOTICE
<ul style="list-style-type: none"> • Changeout of the cartridge can be done easily without having to remove the Series 76T Valve body from the piping system. • Depressurize and drain the piping system, then remove the cap from the Series 76T Valve body to gain access to the cartridge, as described in step 3.

* Teflon is a registered trademark of the DuPont Company

Automatic Balancing Valves

SERIES 76T VALVE, SERIES 76K VALVE WITH UNION INLET, SERIES 76B VALVE WITH BALL VALVE, SERIES 76V VALVE WITH UNION INLET AND BALL VALVE, AND SERIES 76S VALVE WITH SWEAT ENDS

SERIES 76T VALVE BODY TABLE

Size inches	DN	Applicable Cartridge Type
1/2	DN 15	10, 11, 20
3/4	DN 20	
1	DN 25	
1	DN 25L	30, 40
1 1/4	DN 32	
1 1/2	DN 40	
2	DN 50	

Series 76T Valve Body

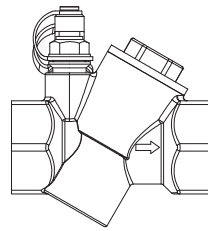

Identification Tag Filled Out and Attached to the Series 76T Valve Body at the Factory

6579 Rev. A 200076T001

Order Code: _____

Cartridge Options:

GPM: _____

Low Pressure: (43.5 psid Maximum)

High Pressure: (87.0 psid Maximum)

Size:

1/2" 3/4" 1" High Flow

1" 1 1/4"

1 1/2" 2" _____

Options:

With Ball Valve (76B)

With Union Inlet (76K)

With Ball Valve and Union Inlet (76V)

QUICK REFERENCE FOR ORIFICE PLATE AND CARTRIDGE MARKINGS

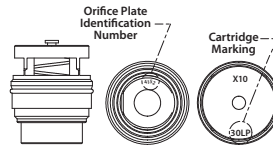
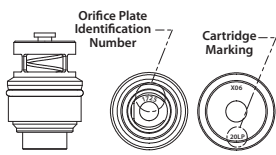

Flow Rate GPM	Orifice Plate Identification Number	Low-Pressure Cartridge		High-Pressure Cartridge	
		Victaulic Code	Marking	Victaulic Code	Marking
0.11	1150	1A	10LP	-	10HP
0.15	1170	1B			
0.20	1190	1C			
0.24	1210	1D			
0.33	1230	1E			
0.39	1260	1F			
0.46	1290	1G			
0.50	1300	1H			
0.57	1320	1I			
0.68	1350	1J			
0.77	1370	1K			
0.90	1400	1L	11LP	11HP	
1.06	1430	1M			
1.23	1460	1N			
1.41	1490	1O			
1.50	1510	1P			
1.80	1540	1Q			
2.10	1570	1R			
2.40	1620	1S			
2.71	1725	1T			
2.95	1730	1U			
3.24	1735	1V	20LP	20HP	
3.52	1740	1W			
3.83	1745	1X			
4.12	1750	1Y			
4.49	2070	2A			
4.76	2074	2B			
5.26	2077	2C			
5.88	2082	2D			
6.53	2086	2E			
6.96	2088	2F			
7.81	2092	2G			
8.07	2094	2H			
9.16	2099	2I			
9.91	2103	2J			
10.21	2106	2K			
10.78	2109	2L			

Flow Rate GPM	Orifice Plate Identification Number	Low-Pressure Cartridge		High-Pressure Cartridge	
		Victaulic Code	Marking	Victaulic Code	Marking
2.97	3073	3A	30LP	CA	30HP
3.79	3082	3B		CB	
4.49	3089	3C		CC	
5.00	3094	3D		CD	
5.24	3096	3E		CE	
5.60	3098	3F		CF	
5.94	3102	3G		CG	
6.54	3107	3H		CH	
6.90	3111	3I		CI	
7.18	3112	3J		CJ	
7.99	3118	3K	CK		
8.81	3124	3L	CL		
9.00	3125	3M	CM		
9.56	3129	3N	CN		
10.00	3132	3O	CO		
10.48	3135	3P	CP		
11.00	3138	3Q	CQ		
11.62	3142	3R	CR		
12.64	3148	3S	CS		
14.05	3156	3T	CT		
15.00	3161	3U	CU		
15.35	3163	3V	CV		
16.00	4148	4A	40LP	DA	40HP
16.20	4152	4B		DB	
18.00	4156	4C		DC	
19.00	4164	4D		DD	
19.99	4168	4E		DE	
20.99	4173	4F		DF	
21.99	4176	4G		DG	
23.99	4182	4H		DH	
25.99	4191	4I		DI	
28.00	4194	4J		DJ	
29.99	4200	4K	DK		
31.99	4205	4L	DL		
33.99	4211	4M	DM		
35.99	4217	4N	DN		
37.99	4222	4O	DO		
39.99	4229	4P	DP		
41.99	4235	4Q	DQ		
43.98	4241	4R	DR		
45.98	4248	4S	DS		
47.98	4250	4T	DT		
49.99	4362	4U	DU		

For complete contact information, visit www.victaulic.com

I-76T 6580 REV A UPDATED 07/2012 Z00076T000

VICTAULIC IS A REGISTERED TRADEMARK OF VICTAULIC COMPANY. © 2012 VICTAULIC COMPANY. ALL RIGHTS RESERVED. PRINTED IN THE USA.

