

High Pressure, Proportional Pressure Reducing Valve

Description

The Model 820-PP will regulate to maintain a constant fixed ratio between upstream and downstream pressure regardless of flow fluctuations created by system demand.

Pressure differential acting on predesigned actuation areas in the valve allows modulation to a fixed ratio of pressure. If upstream pressure rises or falls, downstream pressure will follow in the same fixed ratio.

Installation

1. Allow enough room around the valve assembly for making adjustments and for future maintenance and disassembly work.
2. Thoroughly flush the pipeline to remove dirt, scale, and debris. Failure to perform this operation may render the valve inoperable.
3. It is recommended that isolation valves be installed upstream and downstream of the Bermad pressure reducing system to allow for future maintenance operations.
4. Install the valve in the pipeline with the valve flow arrow on the body casting in the proper direction. Install the valve horizontally with the cover up for best performance. Make certain the valve is positioned so the cover assembly can be easily removed for future maintenance requirements.
5. It is recommended to install a pressure gauge at downstream side.
6. After installation carefully inspect/correct any damaged accessories, piping, tubing, or fittings.

Commissioning & Calibration

1. Confirm that cock valve [2], is open (handle parallel to cock-valve body).
2. Open fully the upstream isolating valve and partially the downstream isolating valve, to fill-up, in a slow and controlled manner, the consumers line downstream from the pressure reducing system.
3. Confirm that the supply pressure and the flow through the system are typical. If necessary, create flow by opening a hydrant, or reduce the flow/pressure by adjusting the downstream/upstream isolating valves.
4. Vent air from the valve's control loop by loosening cover tube fitting at the highest point, allowing all air to bleed. Retighten the tube fitting eyebolt.
5. Reduction ratios range (P1/P2) from 2.2 to 2.5. The reduction ratios are influenced by the valve size. Allow the pressure that appears in the downstream pressure gauge (installed between the valve and the downstream isolating valve or the second stage control valve) to stabilize, meeting the desired value.
6. After the pressure is stabilized, open fully the downstream isolating valve.
7. Relief Valves should be set 15 psi above system highest possible pressure (max. upstream pressure divided by valve reduction ratio).

Control Loop Diagram

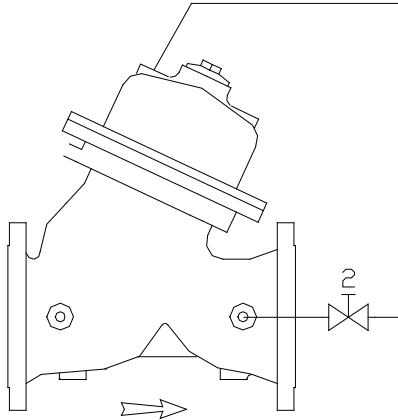

PART LIST

2
800

Ball Valve
Main Valve

Troubleshooting

Symptom

Valve Fails to Open

Cause

- Insufficient inlet pressure.
- No downstream demand.
- Plumbing/Cover/Body tap clogged.
- Ball valve 2 closed.
- Vent hole in the side of the cover is plugged.

Remedy

- Check/create inlet pressure-20 psi min.
- Create demand/flow.
- Clean-out body-cover taps/plumbing
- Open ball valve 2.
- Clean out vent hole (See above drawing).

Valve Fails to Close or Regulate

- Ball valve 2 closed.
- Insufficient inlet pressure/flow.
- Debris trapped in main valve.

- Open ball valve 2.
- Create inlet pressure-20 psi min/flow.
- Remove actuator assembly to inspect seat area/verify valve strokes/remove debris.
- *Check vent side port on partition cover. Continuous flow out of vent port indicates seal damage. Replace the piston seal.

*CAUTION: Valve will be fully open. Close downstream pipeline gate valve or omit this test if this condition may cause system damage.

- *Piston seal in main valve leaking.
- Plumbing/Cover/Body tap clogged.
- Air trapped in main valve cover.
- Vent hole in the side of the cover is plugged.

- Clean-out body-cover taps/plumbing
- Loosen cover tube fitting at highest point. Loosen tube fitting to let air escape. Retighten.
- Clean out vent hole (See above drawing).